

# SRS Circular Column Formwork

For perfect concrete surfaces



Edition 07 | 2013

**PERI GmbH**  
**Formwork Scaffolding Engineering**

P.O. Box 1264

89259 Weissenhorn

Germany

Tel. +49 (0) 7309.950-0

Fax +49 (0) 7309.951-0

info@peri.com

www.peri.com

**Important Notes**

Without exception, all current safety regulations must be observed in those countries where our products are used.

The photos shown in this brochure feature construction sites in progress. For this reason, safety and anchor details in particular cannot always be considered as conclusive or final. These are subject to the risk assessment carried out by the contractor.

Safety instructions and load specifications are to be strictly observed at all times. Separate structural calculations are required for any deviations from the standard design data.

The information contained herein is subject to technical changes in the interests of progress. Errors and typographical mistakes reserved.

# Content

## **SRS Circular Column Formwork**

- 3 The column formwork with high production quality for perfect concrete surfaces
- 4 Variable – Column diameters in 5 cm increments
- 5 Two-piece – Fast assembly with only two column halves and integrated spanner
- 6 Extendable – Four panel heights for height adjustments in 30 cm increments
- 7 Site-compliant details – Safe and fast for perfect circular concrete columns
- 8 Components





# SRS Circular Column Formwork

## High production quality for ensuring perfect concrete surfaces

As formwork for circular columns, PERI SRS prevents the freshly poured concrete from escaping thanks to the special design of the panel joints which results in the realization of perfect concrete surfaces. The SRS column formwork has been designed for a very high fresh concrete pressure of  $150 \text{ kN/m}^2$  which allows fast concreting to take place. The high quality powder coating prevents concrete adhesion and reduces cleaning requirements.

- **Variable**

Column cross-sections in 5 cm increments from 25 to 70 cm, other dimensions on request.

- **Two-piece**

Fast assembly with only two column halves and integrated spanner.

- **Extendable**

Four element heights allow optimal height adjustments in 30 cm increments.



# Variable

## Column diameters in 5 cm increments

With SRS, column diameters from 25 cm to 70 cm can be formed in 5 cm increments. On request, special dimensions up to a diameter of 120 cm are available. The formlining overlap at the joint between the two halves of the formwork ensures tight element joints and prevents bleeding of the concrete.

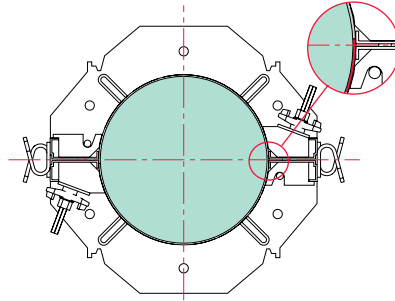

The formlining overlaps at the position where the two column halves meet. This means that the joints are very tight thus preventing any bleeding of the concrete.

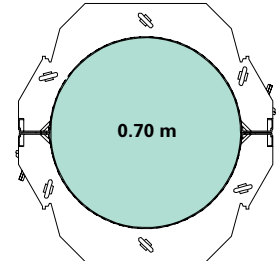
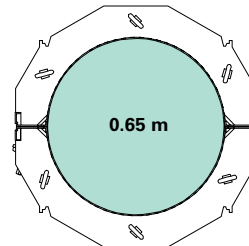
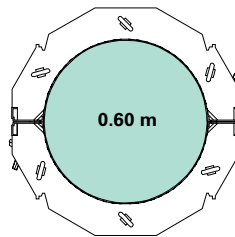
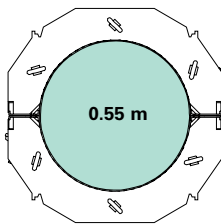
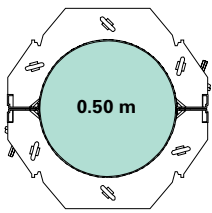
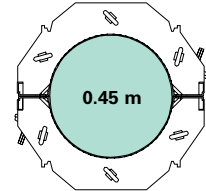
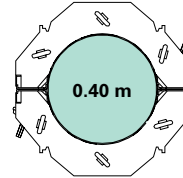
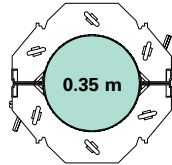
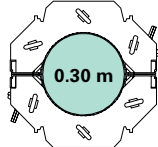
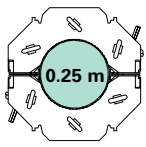

### Using SRS for connecting to panel formwork.

With the PERI BFD Alignment Coupler and the Circular Column Adapter Strip, the SRS column halves can be connected to TRIO and MAXIMO panel formwork as well as to RUNDFLEX circular formwork. The number of BFD alignment couplers used when connecting to panel formwork corresponds to the number of tie yokes.



The TRIO Circular Column Adapter Strip is required only on the side with the formlining offset and replaces a 10 mm thick baton.

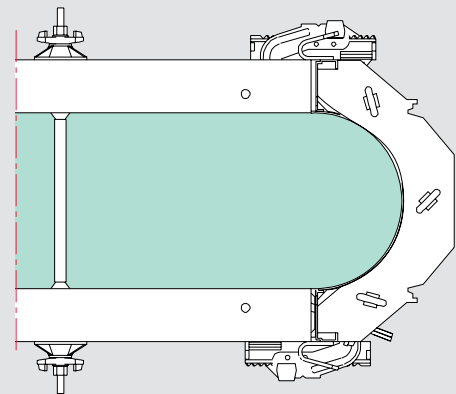



# Two-piece

## Fast assembly with only two column halves and integrated spanner

The SRS column formwork consists of two formwork halves which are braced together. The spanners allow shuttering without any special tools, only a hammer is required.

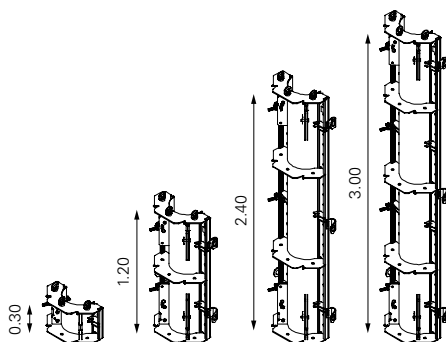

The four element heights (3.00 m, 2.40 m, 1.20 m and 0.30 m) provide ideal height adjustments.



The tie yokes with self-cleaning hexagonal thread are permanently connected to the panel and cannot be lost.



A push-pull prop connection is available on each column panel.



# Extendable

## Four element heights for height adjustments in 30 cm increments

With four panel heights (3.00 m, 2.40 m, 1.20 m and 0.30 m), an optimal height adjustment in 30-cm increments is feasible – up to 8.40 m depending on the column diameter. Height extensions are carried out using ring bolts which are fixed to the panels. Assembly is simple and the ring bolts also serve as crane suspension.

The ring bolts used for extensions are available on each panel. When extending, only a hammer is required.





# Site-compliant details

## Safe and fast for perfect circular concrete columns

Matching concreting platforms and access ladders provide safe working conditions at all heights and for any cross-section. Thanks to the low weight of the SRS circular column platform, assembly can be carried out by hand.



By means of a captive bolt, the telescopic supporting struts of the concreting platform can be adjusted very quickly to suit all column diameters.

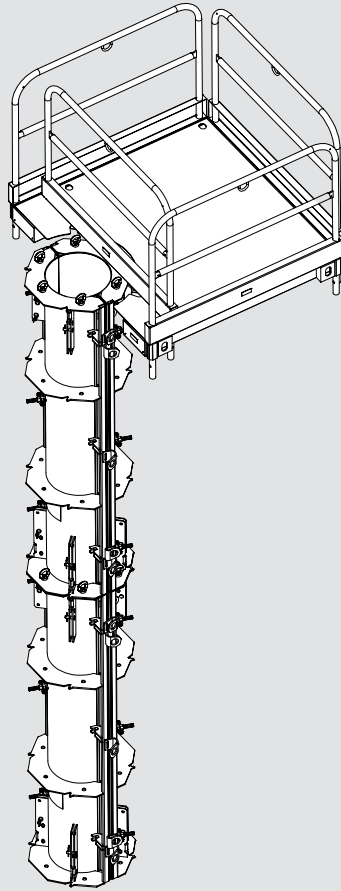

Through the movable guardrail, work can be carried out with both a half-sided concreting platform and all-round scaffold.

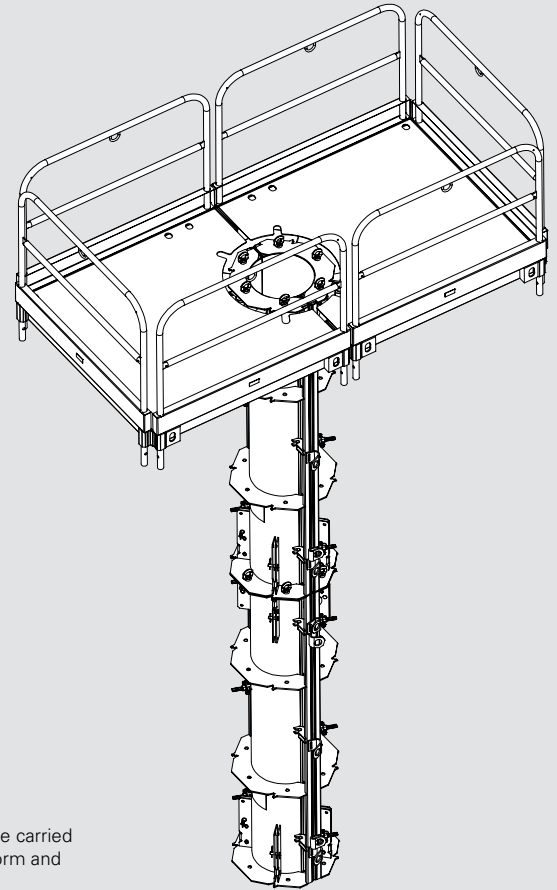

The ring bolt is used to release the two halves of the column - only a hammer is required. This facilitates fast and easy striking.



Integrated stacking aids on the column panels provide safe, non-slip stacks of units. This reduces storage area requirements.



The crane eyes on the column halves serve to ensure easy transportation by crane.



Item no.	Weight kg		B	X	Y
<b>Circular Column Panels</b>					
045010	23,200	Circular Column Panel Ø 25 cm h = 0.3 m	620	290	200
045011	63,000	Circular Column Panel Ø 25 cm h = 1.2 m	620	290	200
045012	98,900	Circular Column Panel Ø 25 cm h = 2.4 m	620	290	200
045013	120,000	Circular Column Panel Ø 25 cm h = 3.0 m	620	290	200
045020	25,200	Circular Column Panel Ø 30 cm h = 0.3 m	670	310	210
045021	67,700	Circular Column Panel Ø 30 cm h = 1.2 m	670	310	210
045022	107,000	Circular Column Panel Ø 30 cm h = 2.4 m	670	310	210
045023	130,000	Circular Column Panel Ø 30 cm h = 3.0 m	670	310	210
045030	26,400	Circular Column Panel Ø 35 cm h = 0.3 m	720	340	210
045031	71,500	Circular Column Panel Ø 35 cm h = 1.2 m	720	340	210
045032	114,000	Circular Column Panel Ø 35 cm h = 2.4 m	720	340	210
045033	139,000	Circular Column Panel Ø 35 cm h = 3.0 m	720	340	210
045040	28,400	Circular Column Panel Ø 40 cm h = 0.3 m	770	360	230
045041	76,300	Circular Column Panel Ø 40 cm h = 1.2 m	770	360	230
045042	123,000	Circular Column Panel Ø 40 cm h = 2.4 m	770	360	230
045043	150,000	Circular Column Panel Ø 40 cm h = 3.0 m	770	360	230
045050	31,000	Circular Column Panel Ø 45 cm h = 0.3 m	820	390	250
045051	82,000	Circular Column Panel Ø 45 cm h = 1.2 m	820	390	250
045052	132,000	Circular Column Panel Ø 45 cm h = 2.4 m	820	390	250
045053	161,000	Circular Column Panel Ø 45 cm h = 3.0 m	820	390	250
045060	32,800	Circular Column Panel Ø 50 cm h = 0.3 m	870	410	240
045061	86,500	Circular Column Panel Ø 50 cm h = 1.2 m	870	410	240
045062	140,000	Circular Column Panel Ø 50 cm h = 2.4 m	870	410	240
045063	171,000	Circular Column Panel Ø 50 cm h = 3.0 m	870	410	240

Circular column panel made of steel. With captive column bolt.

**Note**

Item no. and weight are per column element (half-shell).

**Technical Data**

Load-bearing point capacity 1.0 t.

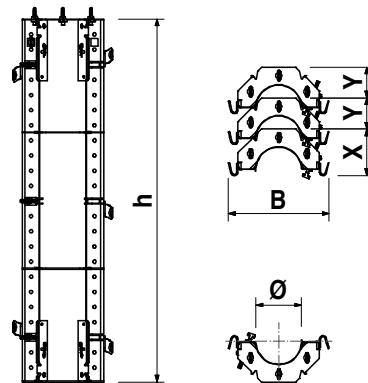
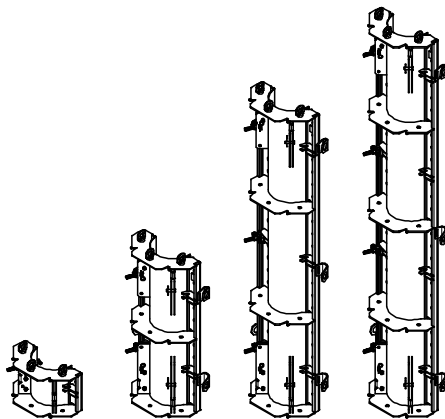

045200 4,070

**Adapter Strip SRS-TRIO l = 3,00 m**

For connecting SRS circular column elements with TRIO panel formwork. Made of aluminium.

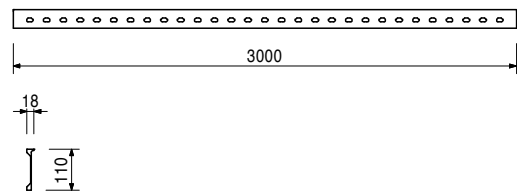
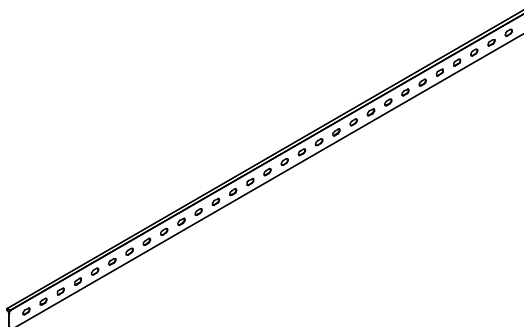



Item no.	Weight kg
045210	135,000

**Circular Column Platform 25-70, compl.**  
 Working and concreting platform for SRS Steel  
 Circular Column Ø 25 cm up to 70 cm.

**Complete with**  
 1 pc. 045211 Circular Column Landing 25-70  
 4 pc. 037430 Platform Guardrail 134, galv.

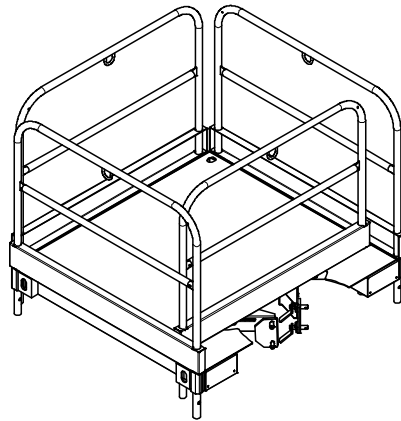

045211	67,000
--------	--------

**Circular Column Landing 25-70**  
 Fits every circular column cross-section from  
 Ø 25 cm to 70 cm in 5 cm increments.

**Technical Data**  
 Permissible load 150 kg/m<sup>2</sup>.

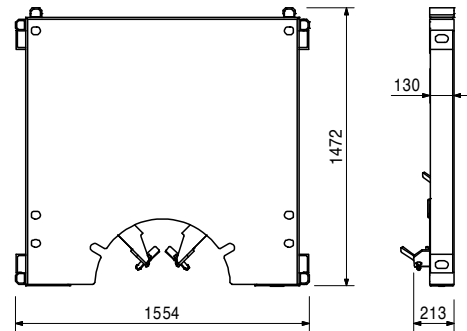
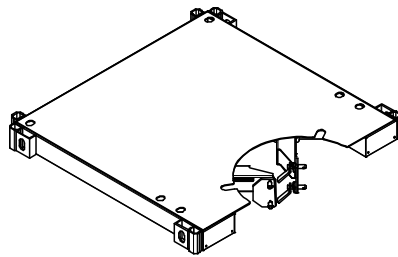

037430	17,100
--------	--------

**Platform Guardrail 134, galv.**  
 As guardrail for PERI Concreting Platforms. Locks  
 in place automatically.

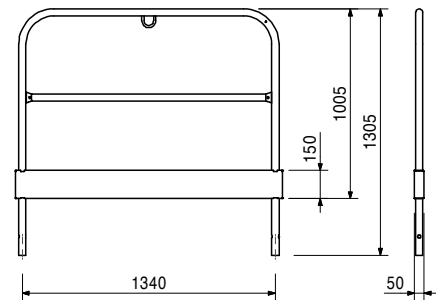
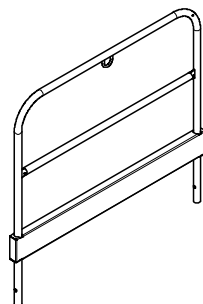

# SRS Column Formwork



Item no.	Weight kg
051410	11,700

**Ladder 180/6, galv.**  
As access for PERI formwork systems.

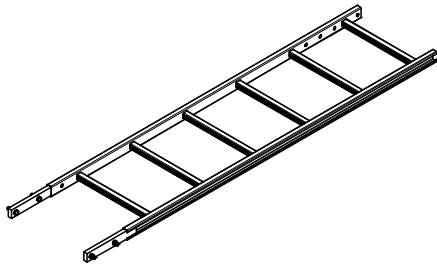

**Complete with**  
4 pc. 710224 Bolt ISO 4017 M12 x 40-8.8, galv.  
4 pc. 710381 Nut ISO 7042 M12-8, galv.

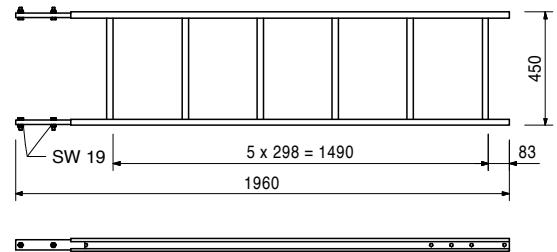

051460	2,180
--------	-------

**Ladder Base, galv.**  
As bottom ladder connection and for securing ladders against sliding on the scaffold decks.

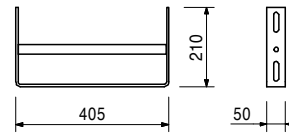
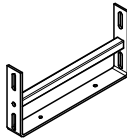

103724	10,400
--------	--------

**End Ladder 180/2, galv.**  
As access for PERI formwork systems.

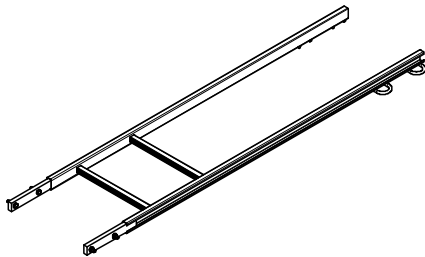

**Complete with**  
4 pc. 710224 Bolt ISO 4017 M12 x 40-8.8, galv.  
4 pc. 710381 Nut ISO 7042 M12-8, galv.

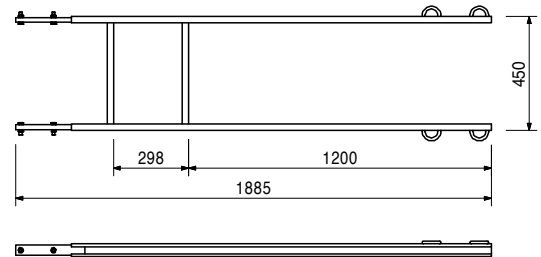

103417	14,100
--------	--------

**Exit Handrail Post SRS 134, galv.**  
For circular column landings 25-70. 1 for each access.

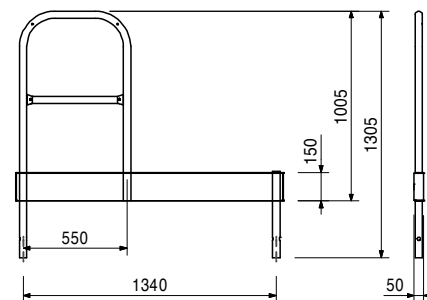
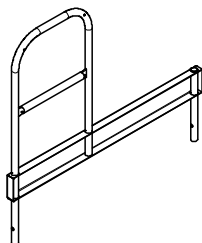



# SRS Column Formwork



Item no.	Weight kg
103718	0,684

**Ladder Hook, galv.**  
For adjusting the bottom ladder.  
Always use in pairs.

**Complete with**  
2 pc. 710266 Bolt ISO 4017 M12 x 25-8.8, galv.  
2 pc. 710381 Nut ISO 7042 M12-8, galv.

**Note**  
Wrench size SW 18.

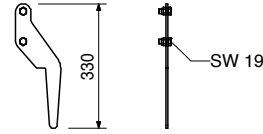

103374	9,710
--------	-------

**Ladder Connector SRS, galv.**  
For connecting ladders to SRS circular column elements up to Ø 70 cm.

**Complete with**  
2 pc. 701763 Clamping Plate FI 25 x 10 x 90  
1 pc. 710266 Bolt ISO 4017 M12 x 25-8.8, galv.

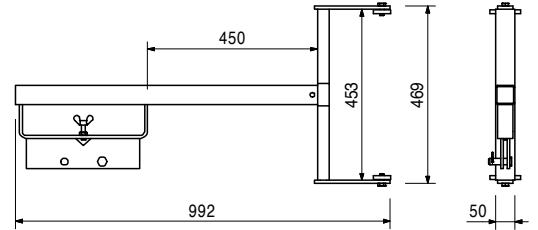
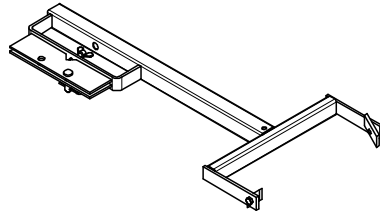

104196	0,698
--------	-------

**SRS Ladder holder**  
For fixing access ladders to the SRS access handrail.  
2 for each ladder.

**Complete with**  
1 pc. 701763 Clamping Plate FI 25 x 10 x 90  
1 pc. 710266 Bolt ISO 4017 M12 x 25-8.8, galv.

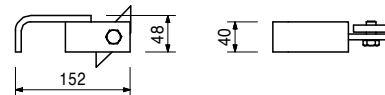
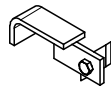

104132	15,600
051450	25,200

**Ladder Safety Cages, galv.**  
**Ladder Safety Cage 75, galv.**  
**Ladder Safety Cage 150, galv.**  
Ladder safety cage for PERI access ladders.

**Complete with**  
4 pc. 710266 Bolt ISO 4017 M12 x 25-8.8, galv.  
4 pc. 701763 Clamping Plate FI 25 x 10 x 90

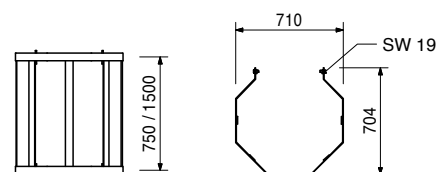
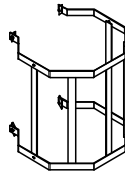

Item no.	Weight kg
117466	10,600

**Push-Pull Prop RS 210, galv.**

Extension length L = 1.30 – 2.10 m.  
For aligning PERI formwork systems and precast concrete elements.

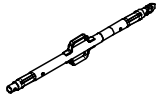

**Note**  
Permissible load see PERI Design Tables.

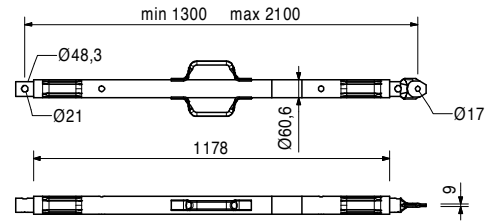

118238	12,100
--------	--------

**Push-Pull Prop RS 260, galv.**

Extension length L = 2.30 – 2.60 m.  
For aligning PERI formwork systems and precast concrete elements.

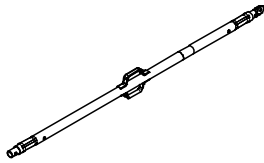

**Note**  
Permissible load see PERI Design Tables.

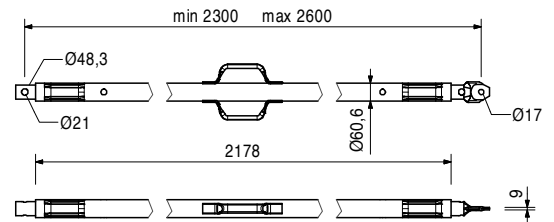

117467	15,400
--------	--------

**Push-Pull Prop RS 300, galv.**

Extension length L = 1.90 – 3.00 m.  
For aligning PERI formwork systems and precast concrete elements.

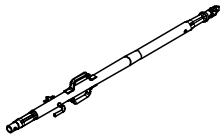

**Note**  
Permissible load see PERI Design Tables.

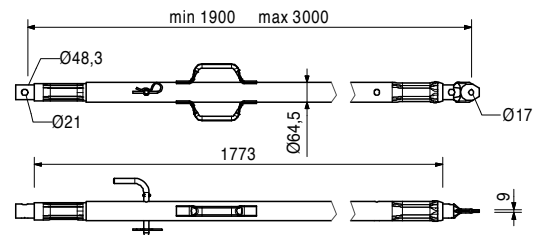

117468	22,900
--------	--------

**Push-Pull Prop RS 450, galv.**

Extension length L = 2.80 – 4.50 m.  
For aligning PERI formwork systems and precast concrete elements.

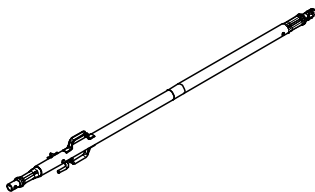

**Note**  
Permissible load see PERI Design Tables.

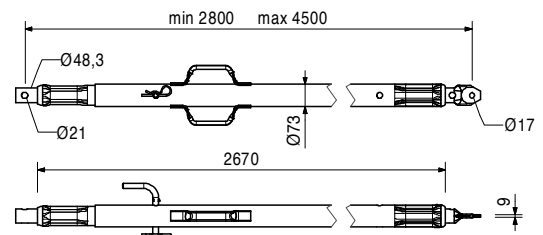



# SRS Column Formwork



Item no.	Weight kg
117469	39,900

**Push-Pull Prop RS 650, galv.**  
 Extension length L = 4.30 – 6.50 m.  
 For aligning PERI formwork systems and precast concrete elements.

**Note**  
 Permissible load see PERI Design Tables.

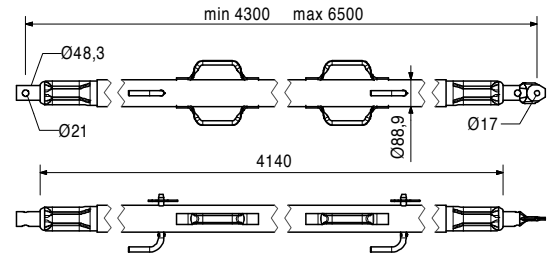
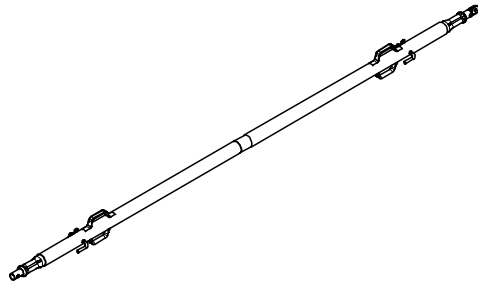

028990	115,000
--------	---------

**Push-Pull Prop RS 1000, galv.**  
 Extension length L = 6.40 – 10.00 m.  
 For aligning PERI formwork systems.

**Note**  
 Permissible load see PERI Design Tables.

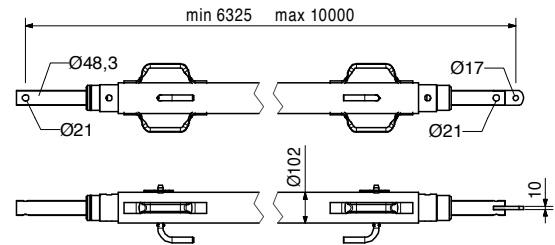
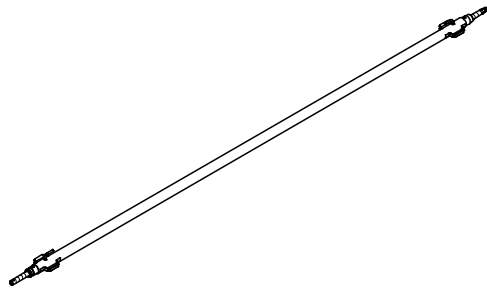

103800	271,000
--------	---------

**Push-Pull Prop RS 1400, galv.**  
 Extension length L = 6.40 – 14.00 m.  
 For aligning PERI formwork systems.

**Note**  
 Permissible load see PERI Design Tables.  
 Chain can be operated from bottom.

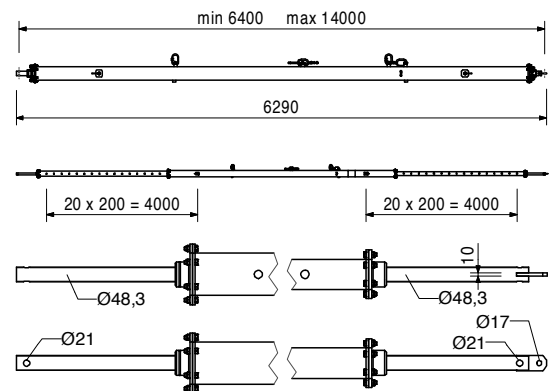
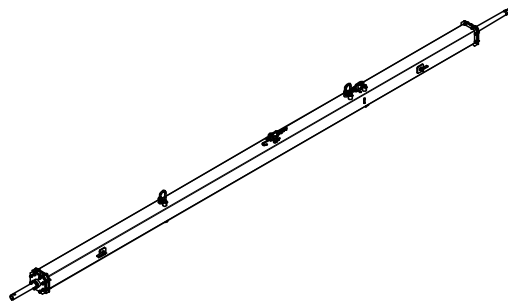

Item no.	Weight kg
117343	3,250

**Base Plate-2 for RS 210 – 1400, galv.**  
For assembly of Push-Pull Props RS 210, 260, 300, 450, 650, 1000 and 1400.

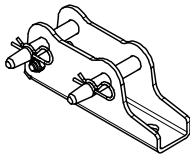

**Complete with**  
2 pc. 105400 Pin Ø 20 x 140, galv.  
2 pc. 018060 Cotter Pin 4/1, galv.

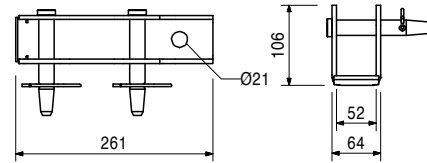

124777	0,210
--------	-------

Accessories  
**Anchor Bolt PERI 14/20 x 130**

028010	18,000
--------	--------

**Push-Pull Prop RSS I**  
Extension length L = 2.05 – 2.94 m.  
For aligning PERI formwork systems.

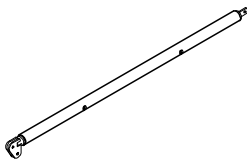

**Note**  
Permissible load: see PERI Design Tables.

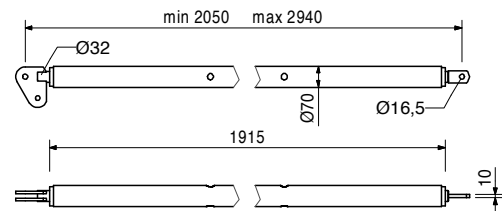

028020	22,100
--------	--------

**Push-Pull Prop RSS II**  
Extension length L = 2.91 – 3.80 m.  
For aligning PERI formwork systems.

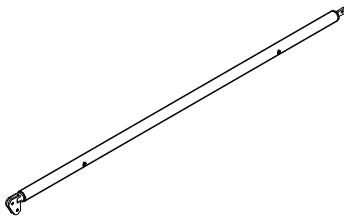

**Note**  
Permissible load: see PERI Design Tables.

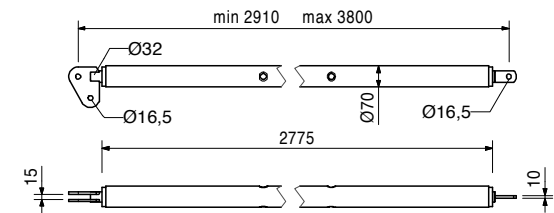

028030	38,400
--------	--------

**Push-Pull Prop RSS III**  
Extension length L = 4.60 – 6.00 m.  
For aligning PERI formwork systems.

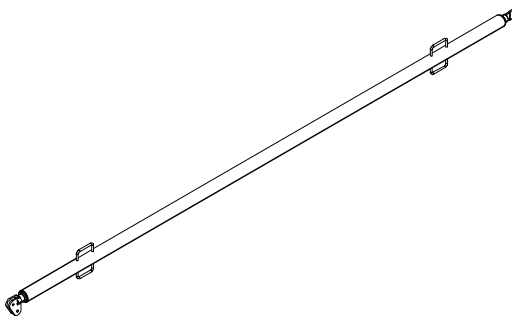

**Note**  
Permissible load: see PERI Design Tables.

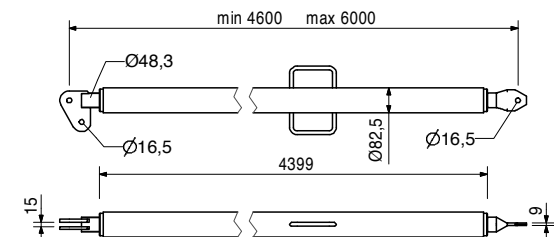

106000	1,820
--------	-------

**Base Plate-2 for RSS, galv.**  
For assembly of RSS push-pull props.

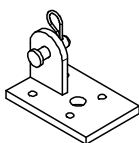

**Complete with**  
1 pc. 027170 Pin Ø 16 x 42, galv.  
1 pc. 018060 Cotter Pin 4/1, galv.

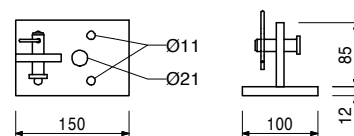

124777	0,210
--------	-------

Accessories  
**Anchor Bolt PERI 14/20 x 130**

Item no.	Weight kg
028110	5,180

**Kicker AV 140**  
 Extension length L = 1.08 – 1.40 m.  
 For aligning PERI formwork systems.

**Complete with**  
 1 pc. 027170 Bolt Ø 16 x 42, galv.  
 1 pc. 018060 Cotter Pin 4/1, galv.

**Note**  
 Permissible load: see PERI Design Tables.

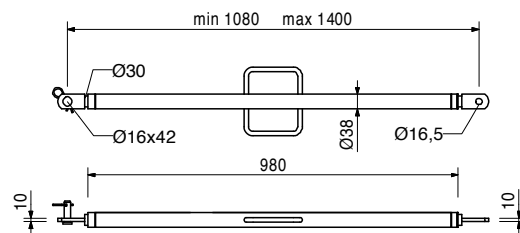
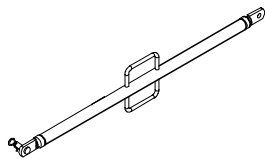

108135	12,900
--------	--------

**Kicker AV 210**  
 Extension length L = 1.28 – 2.10 m.  
 For aligning PERI formwork systems.

**Complete with**  
 1 pc. 027170 Bolt Ø 16 x 42, galv.  
 1 pc. 018060 Cotter Pin 4/1, galv.

**Note**  
 Permissible load: see PERI Design Tables.

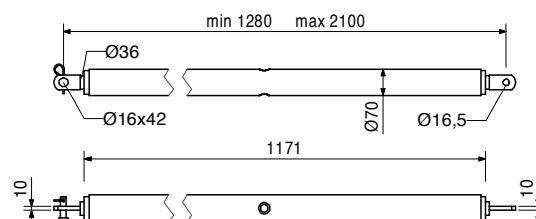
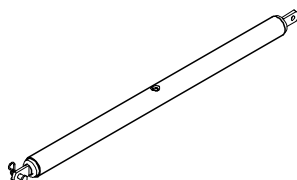

028120	16,900
--------	--------

**Kicker AV RSS III**  
 Extension length L = 2.03 – 2.92 m.  
 For aligning PERI formwork systems.

**Complete with**  
 1 pc. 027170 Pin Ø 16 x 42, galv.  
 1 pc. 018060 Cotter Pin 4/1, galv.

**Note**  
 Permissible load: see PERI Design Tables.

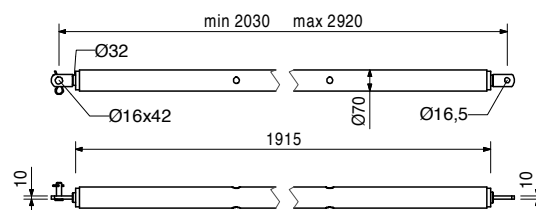
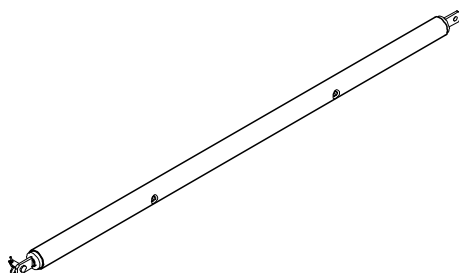

124777	0,210
--------	-------

**Anchor Bolt PERI 14/20 x 130**  
 For temporary fixation on reinforced concrete structures.

**Note**  
 Wrench size SW 24.  
 Drilling Ø 14 mm.  
**Technical Data**  
 See PERI data sheet!

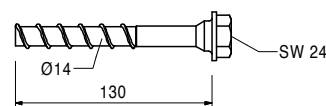
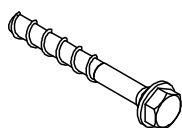



**01 Germany**  
**PERI GmbH**  
 Rudolf-Diesel-Strasse  
 89264 Weissenhorn  
 info@peri.com  
 www.peri.com



**02 France**  
 PERI S.A.S.  
 77109 Meaux Cedex  
 peri.sas@peri.fr  
 www.peri.fr

**03 Switzerland**  
 PERI AG  
 8472 Ohringen  
 info@peri.ch  
 www.peri.ch

**04 Spain**  
 PERI S.A.U.  
 28110 Algete - Madrid  
 info@peri.es  
 www.peri.es

**05 Belgium/Luxembourg**  
 N.V. PERI S.A.  
 1840 Londerzeel  
 info@peri.be  
 www.peri.be

**06 Netherlands**  
 PERI Holding B.V.  
 5480 AH-Schijndel  
 info@peri.nl  
 www.peri.nl

**07 USA**  
 PERI Formwork Systems, Inc.  
 Elkridge, MD 21075  
 info@peri-usa.com  
 www.peri-usa.com

**08 Indonesia**  
 PT Beton Perkasa Wijaksana  
 Jakarta 10210  
 bpw@betonperkasa.com  
 www.peri.com

**09 Italy**  
 PERI S.p.A.  
 20060 Basiano  
 info@peri.it  
 www.peri.it

**10 Japan**  
 PERI Japan K.K.  
 Tokyo 103-0015  
 info@perijapan.jp  
 www.perijapan.jp

**11 United Kingdom/Ireland**  
 PERI Ltd.  
 Rugby, CV23 0AN  
 info@peri.ltd.uk  
 www.peri.ltd.uk

**12 Turkey**  
 PERI Kalip ve Iskeleleri Sanayi  
 ve Ticaret Ltd.  
 Esenyurt / Istanbul 34510  
 info@peri.com.tr  
 www.peri.com.tr

**13 Hungary**  
 PERI Kft.  
 1181 Budapest  
 info@peri.hu  
 www.peri.hu

**14 Malaysia**  
 PERI Formwork Malaysia Sdn. Bhd.  
 43300 Seri Kembangan,  
 Selangor Darul Ehsan  
 info@perimalaysia.com  
 www.perimalaysia.com

**15 Singapore**  
 PERI ASIA Pte. Ltd  
 Singapore 387355  
 pha@periasia.com  
 www.periasia.com

**16 Austria**  
 PERI Ges.mbh  
 3134 Nußdorf ob der Traisen  
 office@peri.at  
 www.peri.at

**17 Czech Republic**  
 PERI spol. s r.o.  
 252 42 Jesenice u Prahy  
 info@peri.cz  
 www.peri.cz

**18 Denmark**  
 PERI Danmark A/S  
 2670 Greve  
 peri@peri.dk  
 www.peri.dk

**19 Finland**  
 PERI Suomi Ltd. Oy  
 05460 Hyvinkää  
 info@perisuomi.fi  
 www.perisuomi.fi

**20 Norway**  
 PERI Norge AS  
 3036 Drammen  
 info@peri.no  
 www.peri.no

**21 Poland**  
 PERI Polska Sp. z o.o.  
 05-860 Płochocin  
 info@peri.com.pl  
 www.peri.com.pl

**22 Sweden**  
 PERIform Sverige AB  
 30262 Halmstad  
 peri@periform.se  
 www.periform.se

**23 Korea**  
 PERI (Korea) Ltd.  
 Seoul 135-936  
 info@perikorea.com  
 www.perikorea.com

**24 Portugal**  
 Pericofragens Lda.  
 2790-326 Queijas  
 info@peri.pt  
 www.peri.pt

**25 Argentina**  
 PERI S.A.  
 B1625GPA Escobar – Bs. As.  
 info@peri.com.ar  
 www.peri.com.ar

**26 Brazil**  
 PERI Formas e  
 Escoramentos Ltda.  
 Vargem Grande Paulista – SP  
 info@peribrasil.com.br  
 www.peribrasil.com.br

**27 Chile**  
 PERI Chile Ltda.  
 Colina, Santiago de Chile  
 perichile@peri.cl  
 www.peri.cl

**28 Romania**  
 PERI România SRL  
 077015 Balotești  
 info@peri.ro  
 www.peri.ro

**29 Slovenia**  
 PERI Agency  
 2000 Maribor  
 peri.slo@triera.net  
 www.peri.com

**30 Slovakia**  
 PERI spol. s. r.o.  
 903 01 Senec  
 info@peri.sk  
 www.peri.sk

**31 Australia**  
 PERI Australia Pty. Ltd.  
 Glendenning NSW 2761  
 info@periaus.com.au  
 www.periaus.com.au

**32 Estonia**  
 PERI AS  
 76406 Saku vald  
 Harjumaa  
 peri@peri.ee  
 www.peri.ee

**33 Greece**  
 PERI Hellas Solely Owned Ltd.  
 194 00 Koropi  
 info@perihellas.gr  
 www.perihellas.gr

**34 Latvia**  
 PERI SIA  
 2118 Salaspils novads, Rigas rajons  
 info@peri-latvija.lv  
 www.peri-latvija.lv

**35 United Arab Emirates**  
 PERI (L.L.C.)  
 Dubai U.A.E.  
 perillc@perime.com  
 www.perime.com

**36 Canada**  
 PERI Formwork Systems, Inc.  
 Bolton, ON – L7E 1K1  
 info@peri.ca  
 www.peri.ca





- 37 Lebanon**  
PERI Representative Office  
90416 – Jdeideh  
lebanon@peri.de  
www.peri.com
- 38 Lithuania**  
PERI UAB  
02300 Vilnius  
info@peri.lt  
www.peri.lt
- 39 Morocco**  
PERI S.A.U.  
Tanger  
peri25@menara.ma  
www.peri.com
- 40 Israel**  
PERI Formwork  
Engineering Ltd.  
Rosh Ha'ayin, 48104  
info@peri.co.il  
www.peri.co.il
- 41 Bulgaria**  
PERI Bulgaria EOOD  
1839 Sofia  
peri.bulgaria@peri.bg  
www.peri.bg
- 42 Iceland**  
Armar ehf.  
220 Hafnarfjörður  
armar@armar.is  
www.armar.is
- 43 Kazakhstan**  
TOO PERI Kazakhstan  
050000 Almaty  
peri@peri.kz  
www.peri.kz
- 44 Russian Federation**  
OOO PERI  
142407, Noginsk District  
moscow@peri.ru  
www.peri.ru
- 45 South Africa**  
PERI (Pty) Ltd  
7600 Stellenbosch  
info@peri.co.za  
www.peri.co.za
- 46 Ukraine**  
PERI Ukraina  
07400 Brovary  
peri@peri.ua  
www.peri.ua
- 47 Egypt**  
Egypt Branch Office  
11341 Nasr City /Cairo  
info@peri.com.eg  
www.peri.com.eg
- 48 Serbia**  
PERI – Oplate d.o.o.  
22310 Šimanovci  
office@peri.rs  
www.peri.rs
- 49 Mexico**  
PERI Cimbras y Andamios,  
S.A. de C.V.  
Estado de México, Huehuetoca  
info@peri.com.mx  
www.peri.com.mx
- 50 Azerbaijan**  
PERI Representative Office  
Baku  
peribaku@peri.com.tr  
www.peri.com.tr
- 51 Turkmenistan**  
PERI Kalıp ve İskeleleri  
Aşgabat  
ahmet.kadioglu@peri.com.tr  
www.peri.com.tr
- 52 Belorussia**  
IOOO PERI Belarus  
220100 Minsk  
info@peri.by  
www.peri.by
- 53 Croatia**  
PERI oplate i skele d.o.o.  
10 250 Lučko-Zagreb  
info@peri.com.hr  
www.peri.com.hr
- 54 India**  
PERI (India) Pvt Ltd  
Mumbai – 400064  
info@peri.in  
www.peri.in
- 55 Jordan**  
PERI GmbH - Jordan  
11947 Amman  
jordan@peri.com  
www.peri.com
- 56 Kuwait**  
PERI Kuwait Company WLL  
13011 Kuwait  
kuwait@peri.com  
www.peri.com
- 57 Saudi Arabia**  
PERI Saudi Arabia Com. Ltd.  
21463 Jeddah  
info@peri.com.sa  
www.peri.com.sa
- 58 Qatar**  
PERI Qatar LLC  
P.O.Box: 31295 - Doha  
info@periqatar.com  
www.periqatar.com
- 59 Algeria**  
SarI PERI  
Kouba 16092, Alger  
info@peri.com  
www.peri.com
- 60 Albania**  
PERI formwork and  
scaffolding Sh.p.k.  
Tirane  
erti.hasanaj@peri.com.tr  
www.peri.com.tr
- 61 Peru**  
PERI Peruana S.A.C.  
Villa El Salvador, Lima  
contacto@peri.com.pe  
www.peri.com.pe
- 62 Panama**  
PERI Panama Inc.  
0832-00155 Panama City  
info@peri.com.pa  
www.peri.com.pa
- 63 Angola**  
Pericofragens, Lda.  
Luanda  
renato.portugal@peri.pt  
www.peri.pt
- 64 Nigeria**  
Heights Access Nigeria Ltd.  
Victoria Island, Lagos  
info@heightsaccessng.com  
www.heightsaccessng.com
- 65 Oman**  
PERI (L.L.C.)  
Muscat  
perimct@perime.com  
www.perime.com
- 66 Colombia**  
PERI S.A.S. Colombia  
Chapinero Alto, Bogotá  
peri.colombia@peri.com.co  
www.peri.com.co

**The optimal System  
for every Project and  
every Requirement**



**Wall Formwork**



**Column Formwork**



**Slab Formwork**



**Climbing Systems**



**Bridge Formwork**



**Tunnel Formwork**



**Shoring Systems**



**Construction Scaffold**



**Facade Scaffold**



**Industrial Scaffold**



**Access**



**Protection Scaffold**



**Safety Systems**



**System-Independent Accessories**



**Services**



**PERI GmbH**  
**Formwork Scaffolding Engineering**  
 Rudolf-Diesel-Strasse 19  
 89264 Weissenhorn  
 Germany  
 Tel. +49 (0) 7309.950-0  
 Fax +49 (0) 7309.951-0  
 info@peri.com  
 www.peri.com